

2

1

ITM	PART NUMBER	QTY	UOM	DESCRIPTION	MATERIAL
1	P4881	2	EACH	U-BOLT - 5/8-11 X 20IN INNER LENGTH X 3.5IN INNER WIDTH - 7IN THREAD LENGTH	STEEL GRADE 5
2	P4882	2	EACH	TIE PLATE FOR U-BOLT - 5/8-11 X 3.5IN INNER WIDTH	STEEL HOT ROLLED 44W
3	000249	4	EACH	WASHER - FLAT - 5/8	STEEL ZINC PLATED
4	000263	4	EACH	WASHER - LOCK - 5/8	STEEL ZINC PLATED
5	P4885	4	EACH	NUT - COUPLING - 5/8-11 X 2.12IN LONG	STEEL ZINC PLATED
6	P4886	2	EACH	SEPARATOR STRIP - 26IN LONG X 3IN WIDE	RUBBER

B

B

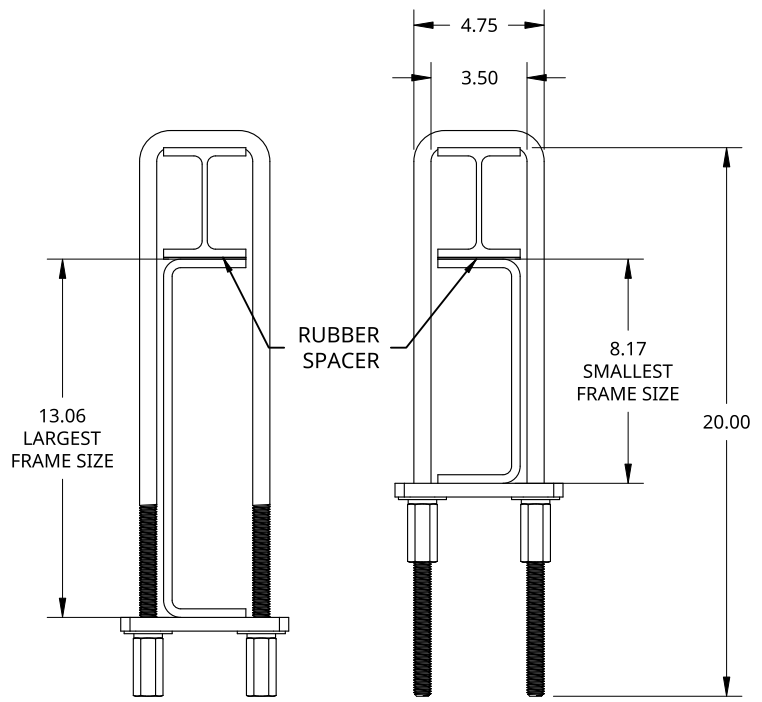

SCALE 1:7

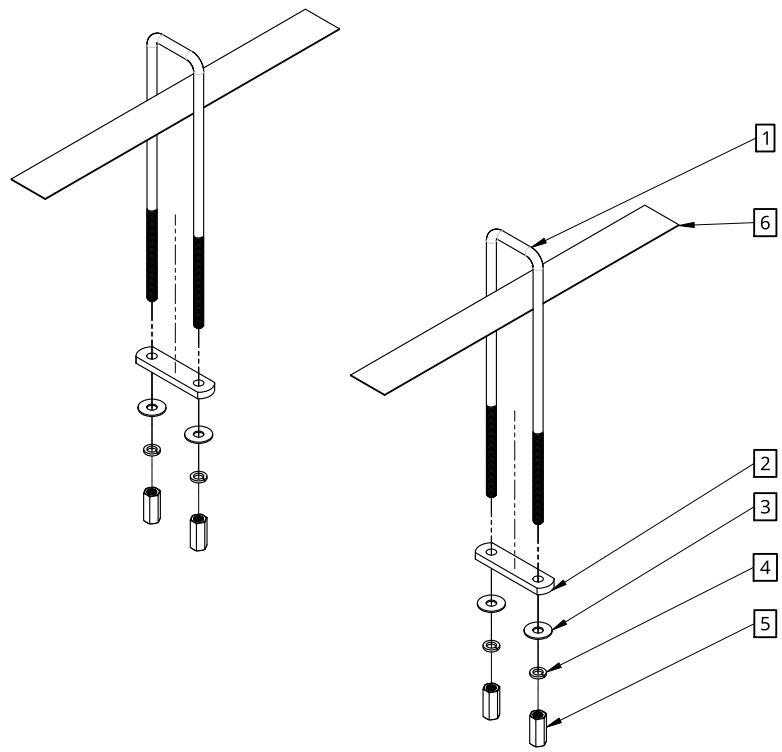

A

A

2

1

<small>THIS DOCUMENT IS THE PROPERTY OF TREBOR MANUFACTURING. ANY UNAUTHORIZED REPRODUCTION WILL BE PROSECUTED TO THE FULL EXTENT OF THE LAW</small>				PART NO. TRU14110/2		REV. A
UNLESS OTHERWISE SPECIFIED, DIMENSIONS ARE IN INCHES .XX = ±.1- .XXX = ±.015- .XXXX = ±.005-		ANGULAR = ±1° FRACTIONAL = ±1/8		CAB SHIELD U-BOLT KIT FOR STANDARD CAB SHIELDS WITH X2 U-BOLTS		
THIRD ANGLE PROJECTION 		MATERIAL GRADE 5		SIZE A DWG NO. D25194		REV. A
				SCALE 1:12 WEIGHT 11.48 LB SHEET 1 of 1		