

2

1

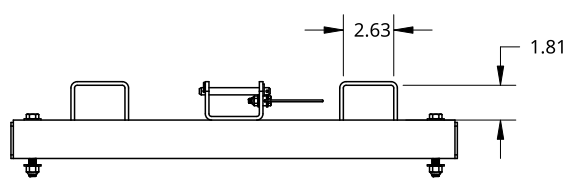
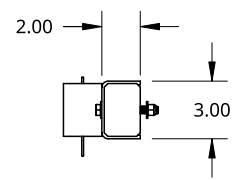
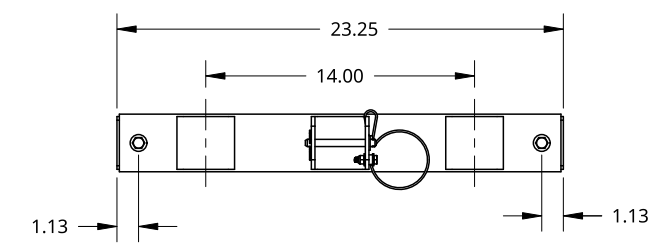
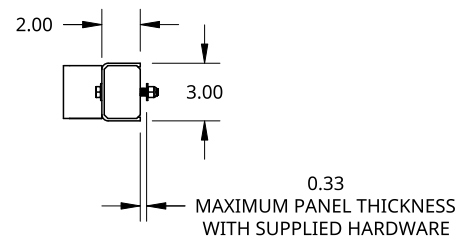
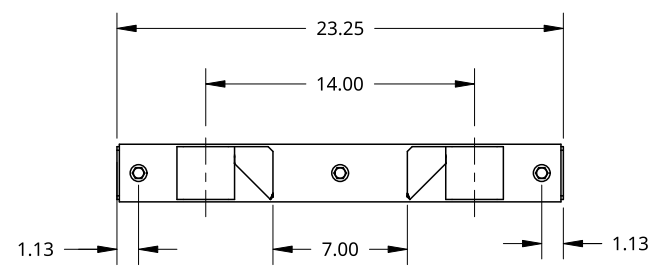
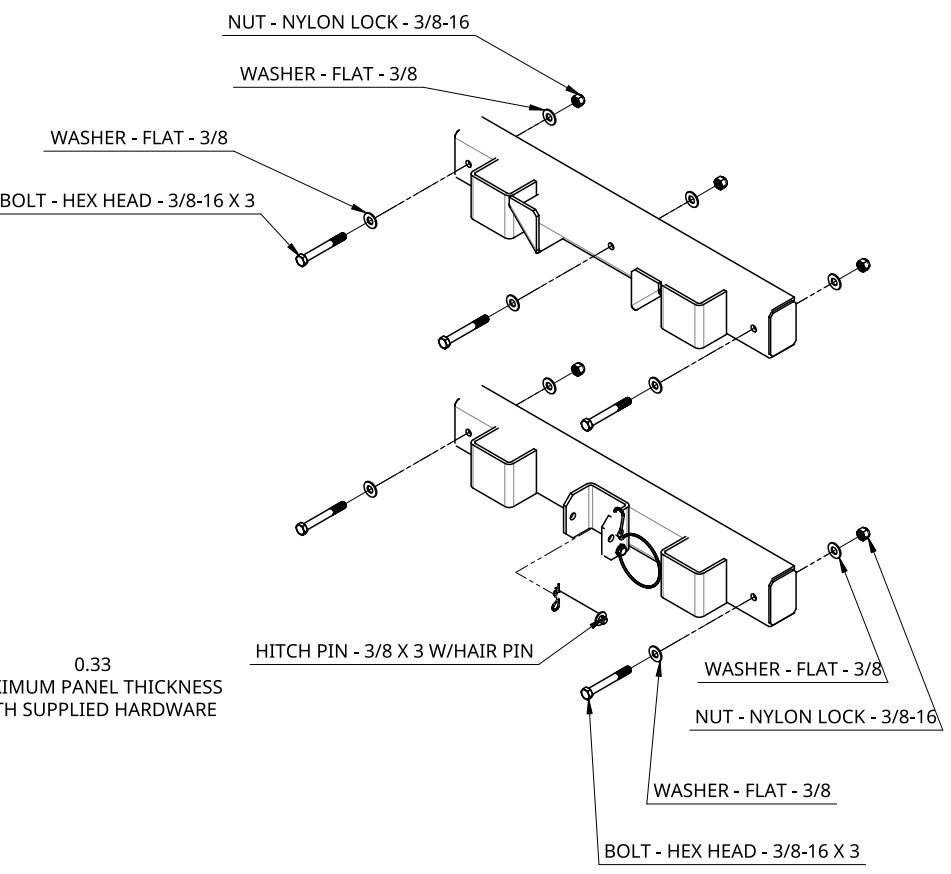
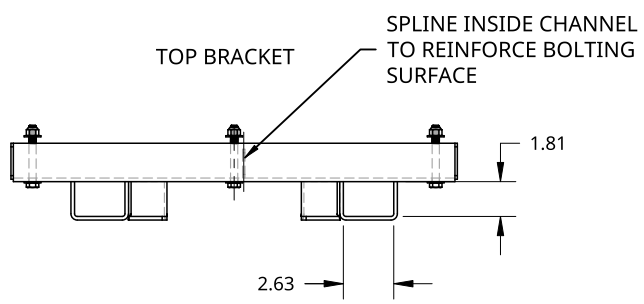

BOTTOM BRACKET

2

1

THIS DOCUMENT IS THE PROPERTY OF TREBOR MANUFACTURING. ANY UNAUTHORIZED REPRODUCTION WILL BE PROSECUTED TO THE FULL EXTENT OF THE LAW.



PART NO. **TRTOOLHOLDERS**
 TOOL HOLDER KIT FOR MOUNTING TO CAB SHIELDS

UNLESS OTHERWISE SPECIFIED, DIMENSIONS ARE IN INCHES
 .XX = ±.1-
 .XXX = ±.015-
 .XXXX = ±.005-
 ANGULAR = ±1°
 FRACTIONAL = ±1/8

DRAWN SHAWN CROCKER 12/09/2020

THIRD ANGLE PROJECTION

MATERIAL



ALUMINUM

SIZE	A		DWG. NO.	D0667		REV	A1
SCALE	1:10	WEIGHT	8.41 LB	SHEET	1 of 1		