

2

1

LOCKING WHALE TAIL HANDLE

1/8 ALU CHECKER DOOR

1/8 ALU CHECKER BODY

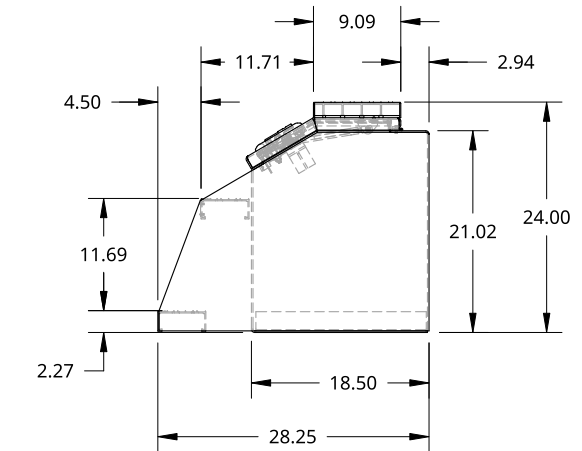
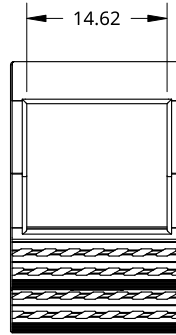

GAS SPRING DOOR HOLDER

13.49

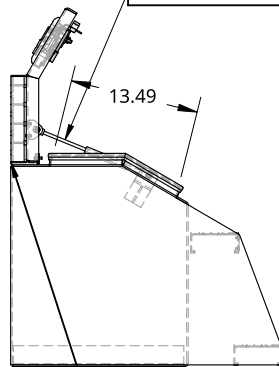

FLUSH WITH BACK OF BOX WHEN OPEN TO 90 DEG

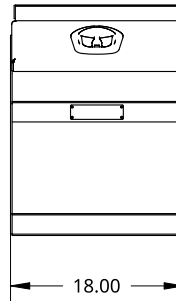

B

B

A

A

2

1

THIS DOCUMENT IS THE PROPERTY OF TREBOR MANUFACTURING. ANY UNAUTHORIZED REPRODUCTION WILL BE PROSECUTED TO THE FULL EXTENT OF THE LAW



PART NO. TRSTBBM18WT

REV. B

UNLESS OTHERWISE SPECIFIED, DIMENSIONS ARE IN INCHES

.XX = ±.1-
.XXX = ±.015-
.XXXX = ±.005-
ANGULAR = ±1°
FRACTIONAL = ±1/8

DRAWN BY	SHAWN CROCKER	07/15/2021
CHANGED BY	SHAWN CROCKER	07/05/2023

BIG MOUTH STEP BOX - 28.25 X 24 X 18 - X1 WHALE TAIL - 9IN TOP STEP

THIRD ANGLE PROJECTION

MATERIAL

SIZE A DWG NO. D32688

REV. A



1/8 ALU CHECKER

SCALE	1:20	WEIGHT	43.98 LB	SHEET	1 of 1
-------	------	--------	----------	-------	--------