

2

1

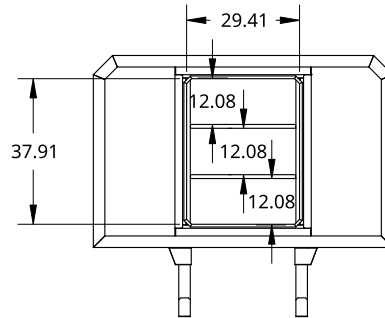
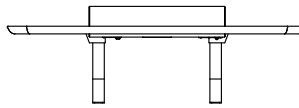

1/8 ALU CHECKER PANELS

T-HANDLE

1/8 ALU CHECKER 3003-H14 DOOR

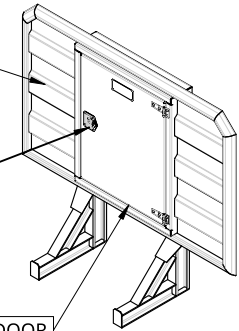

COMPANY NAME
TAB APPROX. LOC.

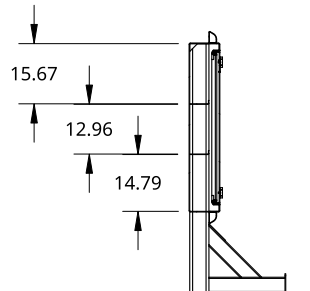

SECTION A - A

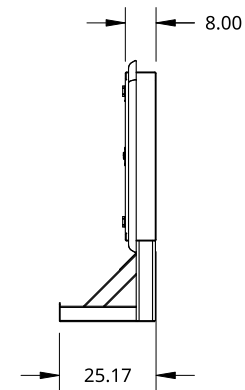
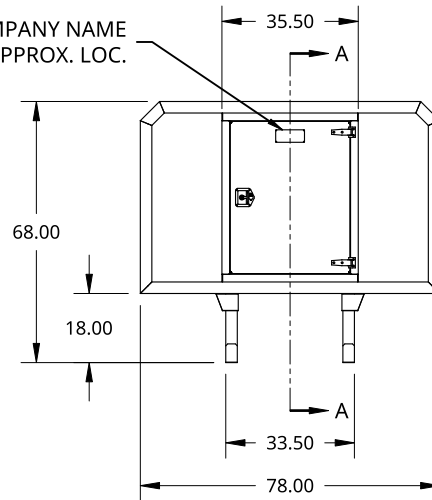

THIS DOCUMENT IS THE PROPERTY OF TREBOR MANUFACTURING. ANY UNAUTHORIZED REPRODUCTION WILL BE PROSECUTED TO THE FULL EXTENT OF THE LAW

UNLESS OTHERWISE SPECIFIED, DIMENSIONS ARE IN INCHES

.XX = ±.1- ANGULAR = ±1°
.XXX = ±.015- FRACTIONAL = ±1/8
.XXXX = ±.005-

THIRD ANGLE PROJECTION

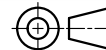

DRAWN SHAWN CROCKER 12/29/2021

MATERIAL

1/8 ALU CHECKER

PART NO. TR6878CC REV. E

CORRUGATED PANEL CAB SHIELD WITH CENTER CABINET - 68 X 78 - CENTER SHELVES - T-HANDLE OPEN RIGHT

SIZE A DWG NO. D4671 REV. C

SCALE 1:50 WEIGHT 185.6 LB SHEET 1 of 1

2

1

B

B

A

A