

2

1

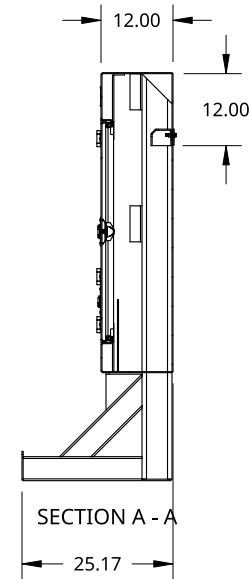
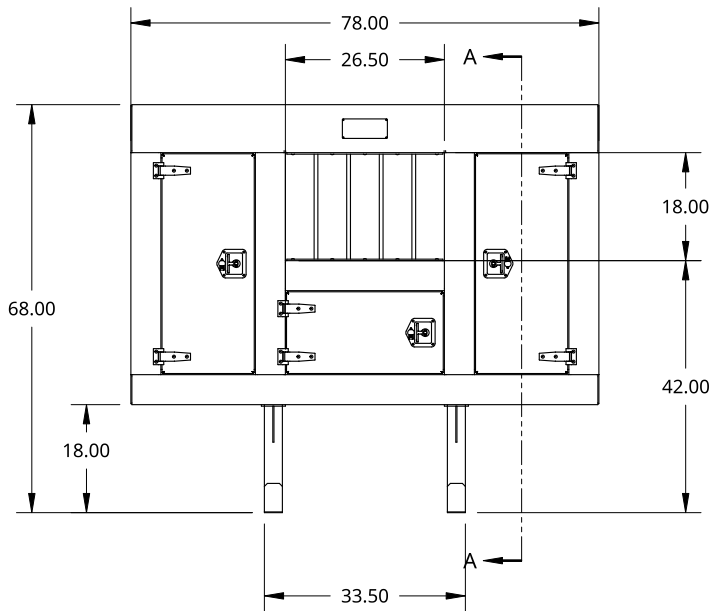
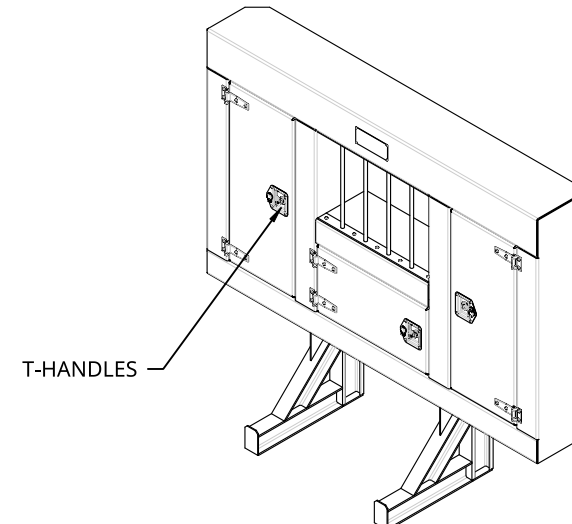
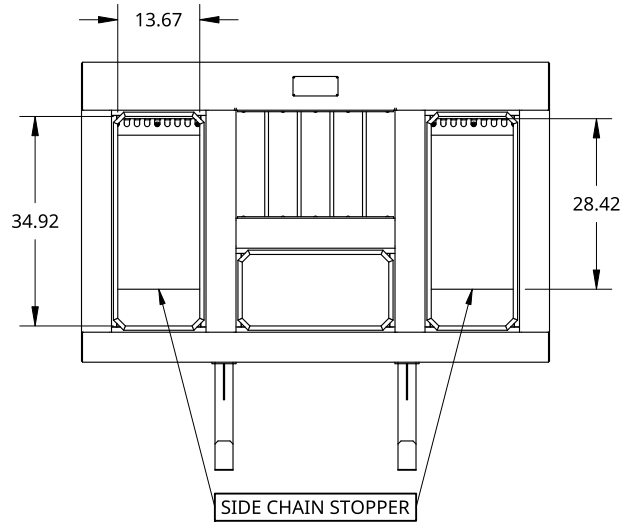

B

B

A

A

THIS DOCUMENT IS THE PROPERTY OF TREBOR MANUFACTURING. ANY UNAUTHORIZED REPRODUCTION WILL BE PROSECUTED TO THE FULL EXTENT OF THE LAW



UNLESS OTHERWISE SPECIFIED, DIMENSIONS ARE IN INCHES
 .XX = ±.1-
 .XXX = ±.015- ANGULAR = ±1°
 .XXXX = ±.005- FRACTIONAL = ±1/8

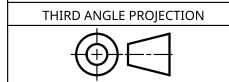

PART NO. **TR3DW6878** REV. **D**

STANDARD COMPARTMENT CAB SHIELD - THREE DOORS W/WINDOW - T-HANDLE - 68IN HIGH X 78IN WIDE

SIZE **A** DWG NO. **D4700** REV. **C**

SCALE **1:32** WEIGHT **278.96 lb** SHEET **1 of 1**

DRAWN BY SHAWN CROCKER 08/11/2021
 CHANGED BY SHAWN CROCKER 12/15/2022

MATERIAL **1/8 ALU CHECKER**

2

1