

SPECIFICATIONS	
OVERALL LENGTH	120.00 IN
OVERALL WIDTH	101.88 IN
HEADBOARD HEIGHT	48.00 IN
MAIN SILL TYPE	3 X 3 X 0.25 ALUM. TUBE
MAIN SILL SPREAD	34.00 IN
DRIVERS SIDE WINCHES WITH 3IN STRAPS 5400LB WLL.	X4
2IN LED CLEARANCE LIGHTS IN FOUR CORNERS	

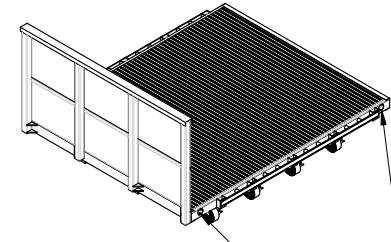

2IN CIRCULAR LIGHT - AMBER LENSE AND LIGHT - UNSEALED 2-WIRE PLUG

2IN CIRCULAR LIGHT - RED LENSE AND LIGHT - UNSEALED 2-WIRE PLUG

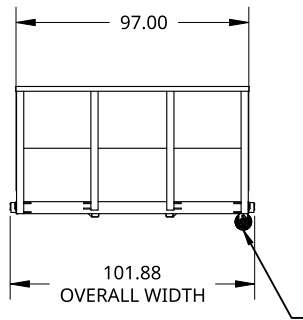

X4 WINCHES AND STRAPS ON DRIVERS SIDE

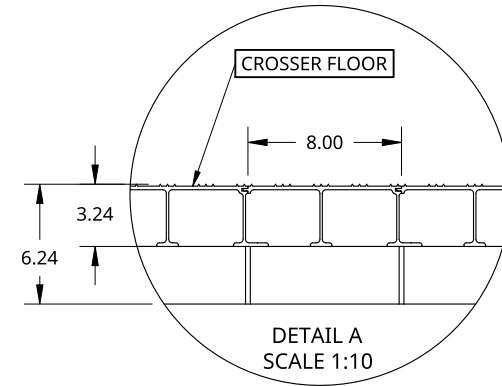
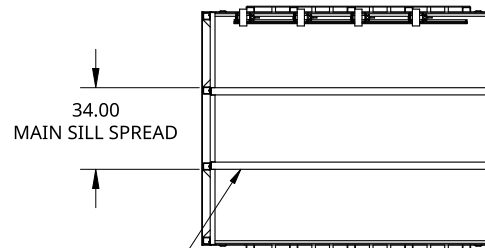
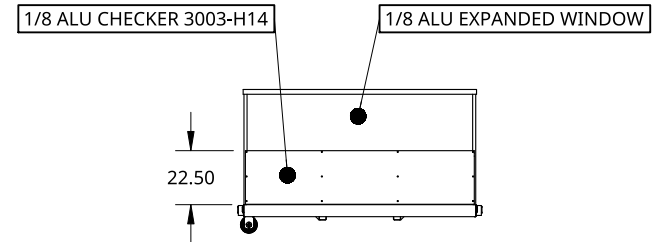
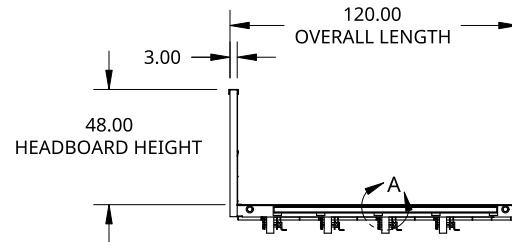

THIS DOCUMENT IS THE PROPERTY OF TREBOR MANUFACTURING. ANY UNAUTHORIZED REPRODUCTION WILL BE PROSECUTED TO THE FULL EXTENT OF THE LAW

UNLESS OTHERWISE SPECIFIED, DIMENSIONS ARE IN INCHES

.XX = ±.1-  
.XXX = ±.015-  
.XXXX = ±.005-  
ANGULAR = ±1°  
FRACTIONAL = ±1/8



PART NO. PFLD10 REV. A

CROSSER FLOOR FLAT DECK - 120IN LONG OVERALL X 101.88IN WIDE WITH POCKETS - X4 WINCHES AND STRAPS ON DRIVERS SIDE

REVISIONS			
REVISION	REVISION DESCRIPTION	DATE APPROVED	APPROVER
A	RELEASED TO MFG	06/08/2022	SHAWN CROCKER

THIRD ANGLE PROJECTION

DRAWN SHAWN CROCKER 06/07/2022

MATERIAL ALUMINUM

SIZE A	DWG NO. D19152	REV. A
SCALE 1:80	WEIGHT 748.59 LB	SHEET 1 of 2

# BASIC BODY CONSTRUCTION

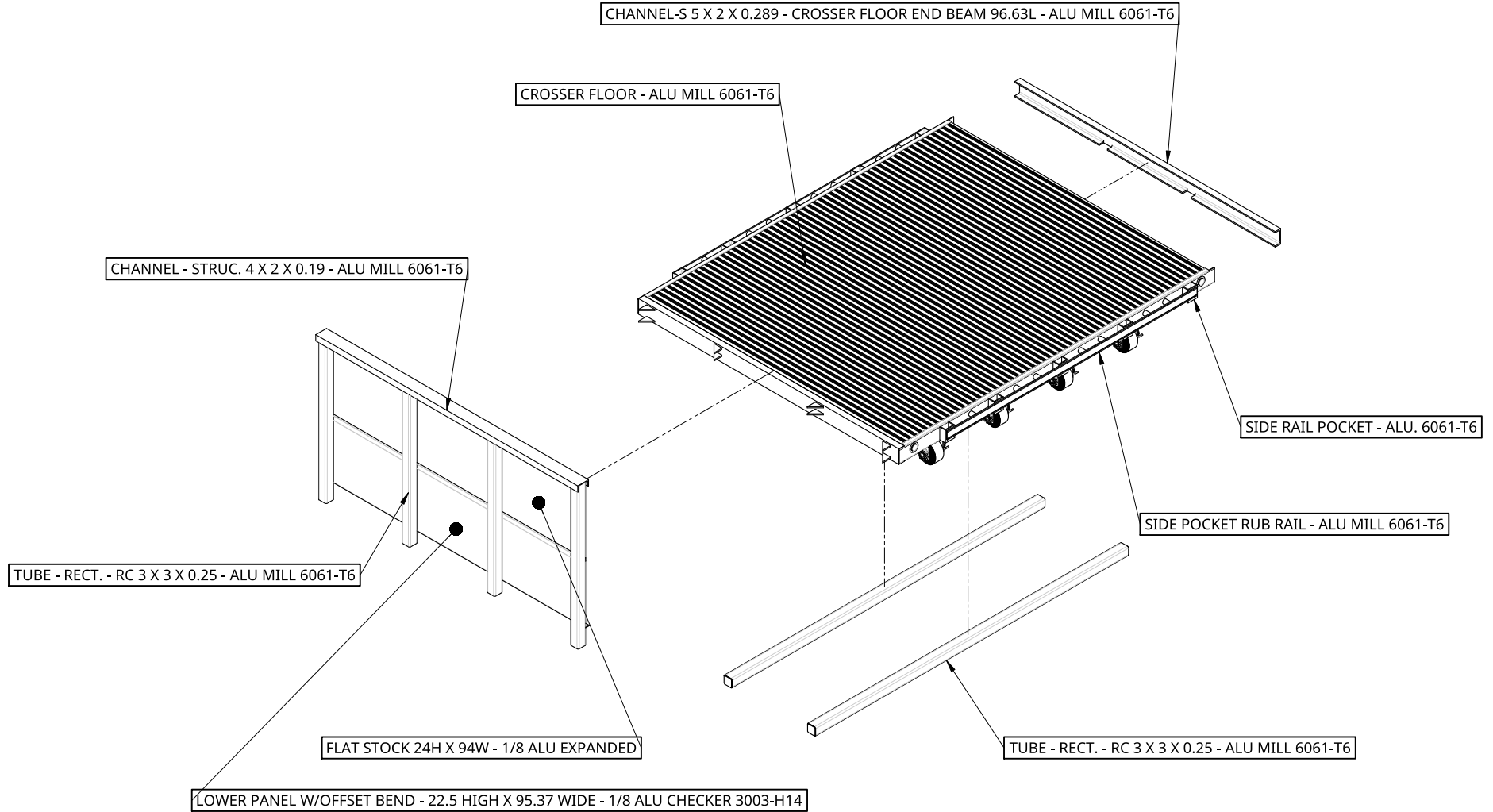

THIS DOCUMENT IS THE PROPERTY OF TREBOR MANUFACTURING. ANY UNAUTHORIZED REPRODUCTION WILL BE PROSECUTED TO THE FULL EXTENT OF THE LAW

UNLESS OTHERWISE SPECIFIED, DIMENSIONS ARE IN INCHES

.XX = ±.1-  
.XXX = ±.015- ANGULAR = ±1°  
.XXXX = ±.005- FRACTIONAL = ±1/8



PART NO. PFLD10 REV. A

CROSSER FLOOR FLAT DECK - 120IN LONG OVERALL X 101.88IN WIDE WITH POCKETS - X4 WINCHES AND STRAPS ON DRIVERS SIDE

SIZE A DWG. NO. D19152 REV. A

SCALE 1:40 WEIGHT 748.59 LB SHEET 2 of 2

REVISIONS
SEE SHEET 1

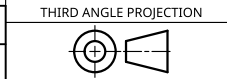

DRAWN SHAWN CROCKER 06/07/2022

MATERIAL ALUMINUM