

REINFORCEMENT FLANGE FORMED INTO
RIGHT AND LEFT BOTTOM CORNERS

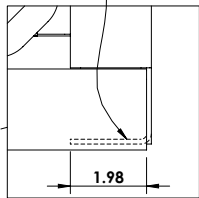

DETAIL B
SCALE 1 : 5

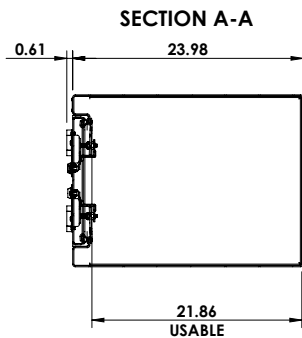
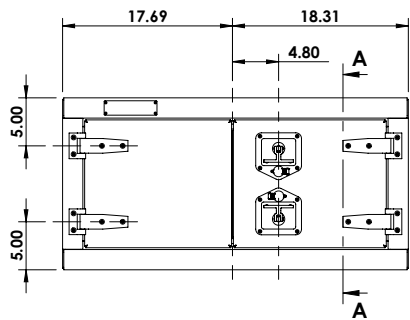
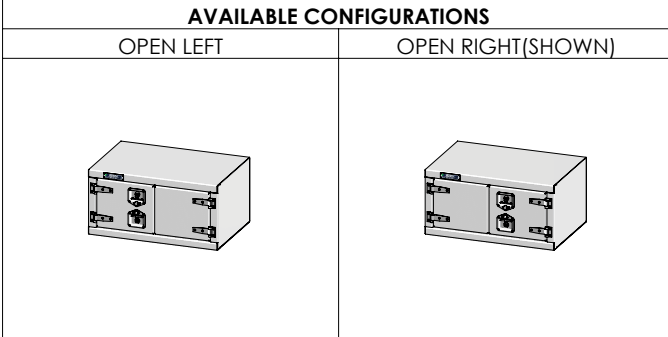

REVISIONS		
REV.	DESCRIPTION	DATE
1	INITIAL RELEASE	01/13/2017

REV: 1		This Document is the sole property of Trebor Manufacturing	
			DATE: 1/13/2017

Dimensions are in inches unless otherwise specified

PART NO: **TRPL1836**

MATERIAL: **0.125 Alum. Plain 3003-H14**

DESCR: **24D" x 18H" x 36W" Under body tool box w/2 doors Right hand, Locking t-handle**

Aprox. Weight: **60.63 LB** Usable Vol.: **8.06 CU. FT.**

TOLERANCES: **.xx ± 0.13" .xxx ± 0.010"**